

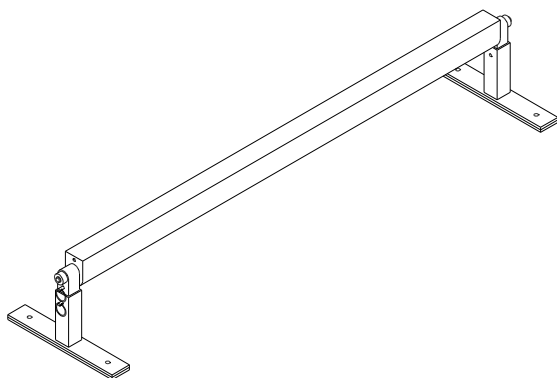

USERS GUIDE

Instruction Manual

(English Version)



A Good Decision:

Congratulations on your purchase of the AIRO DUORAIL. If maintained and used properly, this premium product will give many years of service.

 **Caution:** Please take the time to read this guide before assembling your DUORAIL. Failure to assemble in the proper order may lead to injury.

Step 1 Inspection of Contents:

Before assembling your DUORAIL, make sure all parts were received. If parts are missing or damaged in transit, email us at info@duorail.com.

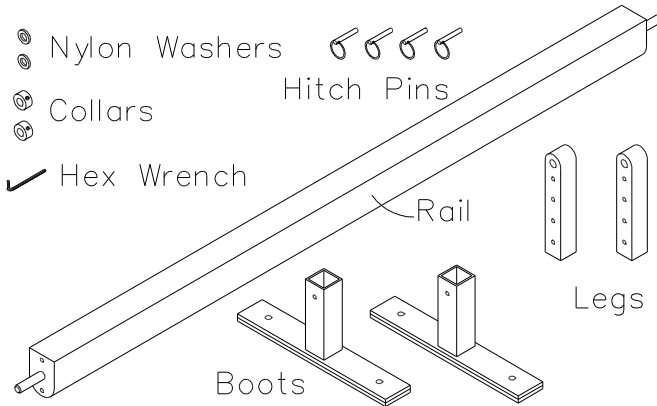

PARTS LIST

<u>Quantity</u>	<u>Description</u>
1	Rail
2	Legs
2	Boots
2	Nylon Washers
2	Collars
4	Hitch Pins
1	1/8 inch Hex
1	Wrench

Step 2 Leg Assembly

Drop one leg all the way into the boot. Insert a hitch pin to secure the leg. Make sure the pin extends out the other side of the boot. Repeat with the second leg and boot.

⚠ Caution: Do not insert the hitch pin into the boot and then drop the leg into the boot. This creates an unstable condition. To be safe, the hitch pin must go through one of the three holes provided for it.

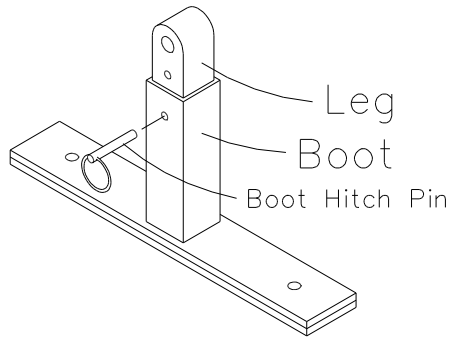

Step 3 Install Nylon Washers:

Slide one white nylon washer onto the axle of the rail. Repeat on the other end of the rail. Without the washer, the rail may not turn easily when rotating from a flat to a curved surface.

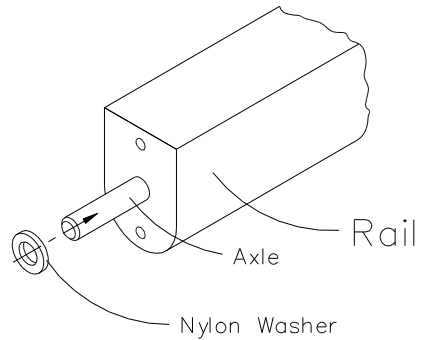

Step 4 Assemble Leg and Boot

Install one leg on an axle. Slide onto the axle the hex wrench and the second leg.

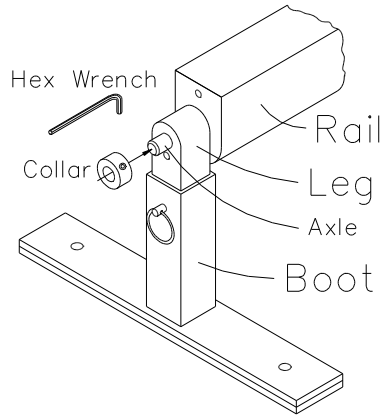

Step 5 Choose Flat or Round

With legs held securely by both collars, you can rotate the rail safely and choose whether you want the flat or round surface up. Install a hitch pin to secure each leg. The flat side up is usually best for beginners.

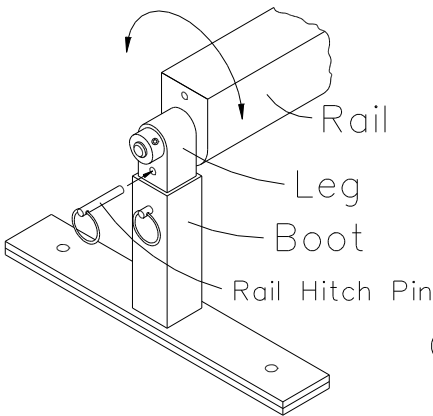

OR

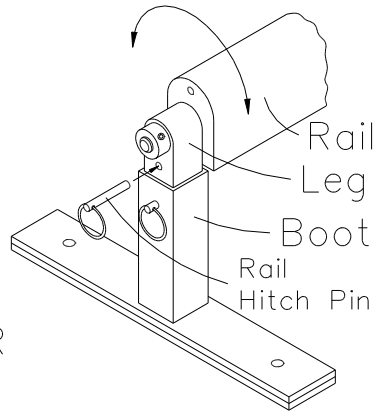

Step 6 Height Adjust

The picture to the right is an exploded view of the leg assembly. Note that the holes provided in each leg. For beginners, we suggest inserting the hitch pin into the top hole which will give you a height of 8 inches off the ground. As you get more experience, you can adjust the height by inserting the hitch pin into the middle or bottom hole.

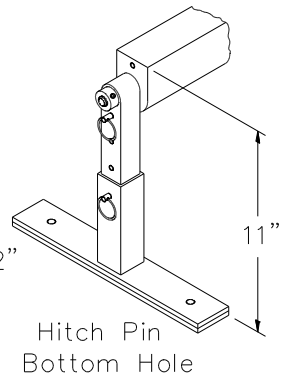
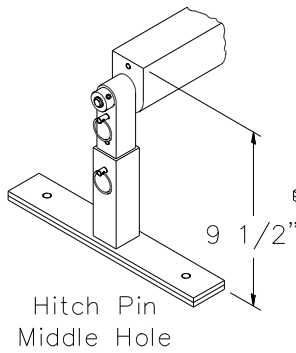
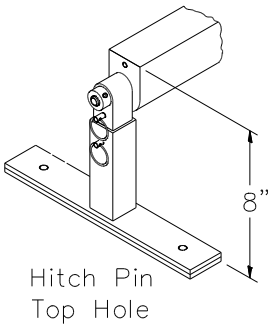
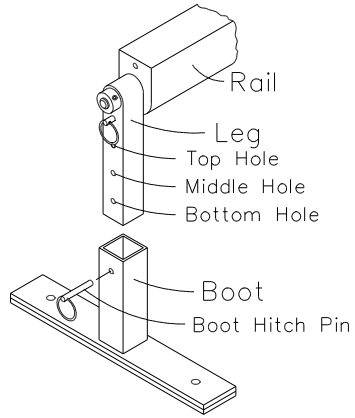

Safety First

Proper Attire

The rider should wear the proper attire that you would ordinarily need when you ride skateboard, bmx or inline. We recommend the following.

Skate shoes or sneakers. No bare feet, sandals, or open-toed shoes.

Long sleeve knit shirt (a skin saver).

Long pants or board shorts (another skin saver).

Wear light colors if you ride at night

Safety Equipment (Recommended)

Always wear: Helmet

Kneepads

Elbow pads

Wrist pads

Check Your Equipment:

Before you ride, examine the DUORAIL to make sure the rail axles are inserted all the way into the legs. The collars must be installed and adjusted tight with the hex wrench.

*****All four hitch pins must be securely in place.**

The boots have rubber soles to minimize slippage of the rail. If any slippage occurs, you must fasten the boots to the floor or roadway. Holes are provided on the boots. You may use 5/16" or 3/8" lag screws (not provided) to fasten the boots to the floor or roadway.

Routine Maintenance

Clean is good. Keep the DUORAIL as clean as possible. All you need is a damp soapy cloth to wipe it down. Don't use harsh detergents, chemicals, or gritty cleaning sponges, which may damage the finish.

Oil it. Occasionally put a few drops of light oil all around the axles and in the hitch pin holes, both on the legs and on the rail. Wipe off any excess oil.

The powder coat finish will scratch. The DUORAIL is made of steel that will rust. We suggest covering the rail at night with a tarp and putting it in a dry place when it rains. The rail should be kept and used in a dry environment. Rub on decent quality skate wax to minimize rust; the wax also improves the performance of your rail.





Warranty

The manufacturer warrants the DUORAIL to be free of manufacturing defects for a period of six months from the date of purchase.

The manufacturer and distributor are not liable for damages from the use or misuse of this product.

It is recommended that the user be at least of ample height and weigh a maximum of 180 pounds (64 kilograms) to use this product.

WARNING

Skateboarding, BMX and Inline sports provide an element of serious risk and or injury, the rider or user releases all responsibility of injury when using the DUORAIL product and indemnifies AIROUSA its agents, affiliates, officers, directors, employees or subsidiaries. AIROUSA will assume no liability for injuries related to the misuse and or inexperience of the rider for the DUORAIL product. All reasonable measures have been taken to ensure a safe and enjoyable experience with the AIRO DUORAIL.

AIROUSA, LTD.

www.airousa.com

info@duorail.com

AIRO DUORAIL (2008 Patented)